

Turntables

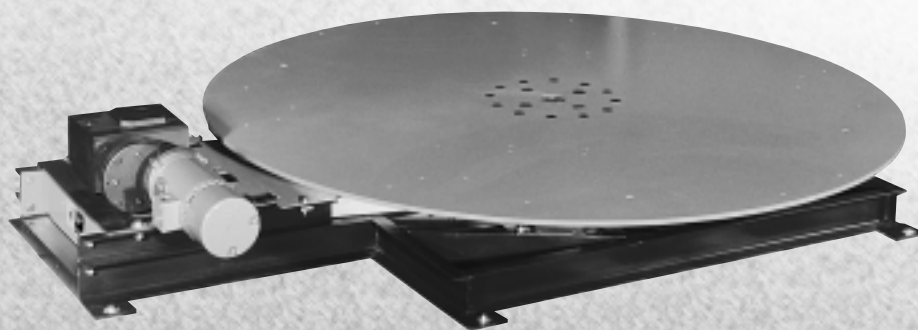

Low Profile Manual Turntables (LPMT).....	236
Manual Turntables	237
Powered Turntables	238

Omni Metalcraft Corp

Low Profile Manual Turntables (LPMT)

A valuable accessory for ergonomic work stations or for confined working areas. These turntables are used for palletizing, un palletizing, assembly, painting...the possibilities are endless!



LPMT Shown With
Optional Stand

LPMT's are manually operated and can be mounted to any rigid flat surface. Some examples would include scissor lifts, table tops or the floor.

Features Include:

- One of the lowest heights in the industry
- Sealed for life yoke rollers
- Thick steel top platform
- Base with pre-drilled holes for mounting
- Corners of table top clipped for safety

Options:

- Other platform sizes available
- Round top platform
- Detent positioning stop
- Manual positioning stop
- Self supporting stand
- Rotary bearing for lower rotational force

Lo-Profile Manual Turntable (Pallet Applications)

Capacity	Model Number	Deck Size	Top Plate Thickness	Min. Top of Table	Support Bearing	Shipping Weight
2,000 lbs.	LPMT-3620	36 in. x 36 in.	1/2 in.	2 1/2 in.	Yoke Roller	245 lbs.
4,000 lbs.	LPMT-3640	36 in. x 36 in.	1/2 in.	2 1/2 in.	Yoke Roller	250 lbs.
2,000 lbs.	LPMT-4820	48 in. x 48 in.	1/2 in.	2 1/2 in.	Yoke Roller	425 lbs.
4,000 lbs.	LPMT-4840	48 in. x 48 in.	1/2 in.	2 1/2 in.	Yoke Roller	435 lbs.

Manual Turntables are used for loading and unloading pallets and containers, as well as improving the ergonomics of workstations.



Turntables are also useful for providing directional change in your conveying line. A section of conveyor can be attached to the table surface and then rotated to the desired position for product flow.

- Light and Heavy Duty Models
- Capacities up to 7,500 lbs.
- Standard Diameters up to 120 in.
- 90°, 180° or 360° Rotation

Capacity	Outer Dia. Max.	Top Plate Thickness	Min. Top of Table	Support Bearing
7,500 lbs.	120 in.	1 in.	10 3/4 in.	Rotary Bearing
5,000 lbs.	102 in.	5/8 in.	10 1/4 in.	H.D. Yoke Roller
3,500 lbs.	84 in.	1/2 in.	8 in.	H.D. Yoke Roller
1,000 lbs.	60 in.	3/8 in.	7 in.	Yoke Roller

Can provide lower heights but requires fully supporting surface. Additional capacities and sizes are available.

Standard Specifications:

Base Frame - Welded structural channel or tube provides rigid support for table top and table top supports in both light duty and heavy duty models.

Top Plate - Rigid, flat sheet top plate provides clean work surface. Turntables can be equipped with a conveyor deck, per customer specifications. Other options are available.

Rotation - Standard table rotations of 90°, 180° or 360°. Other rotations are available upon request.

Detents - Manually operated or spring loaded detents orient table top at 90° increments on all manually operated units. Special increments are available. Manually operated detents can be actuated by hand or foot on request.

Options:

- Limit switches or proximity switches to determine position of table top.
- A slip ring to route power through center of table to rotating deck of turntable. A slip ring may affect the minimum height of table.
- Rotary union to route air or hydraulic oil to rotating deck of turntable. Rotary unions may affect the minimum height of table.
- Gravity transition rollers are standard on units that incorporate a conveyor deck. These transition rollers, which are attached to the rotating part of the turntable, are used to assist in supporting products during the transition from adjoining conveyor to the turntable. Powered transition rollers are also available to aid problem products. Fixed transition rollers can also be mounted to adjoining conveyor.

Powered Turntables

Powered Turntables are useful for providing directional change in your conveying line. A section of conveyor can be attached to the table surface and is then rotated to the desired position for product flow in a system.

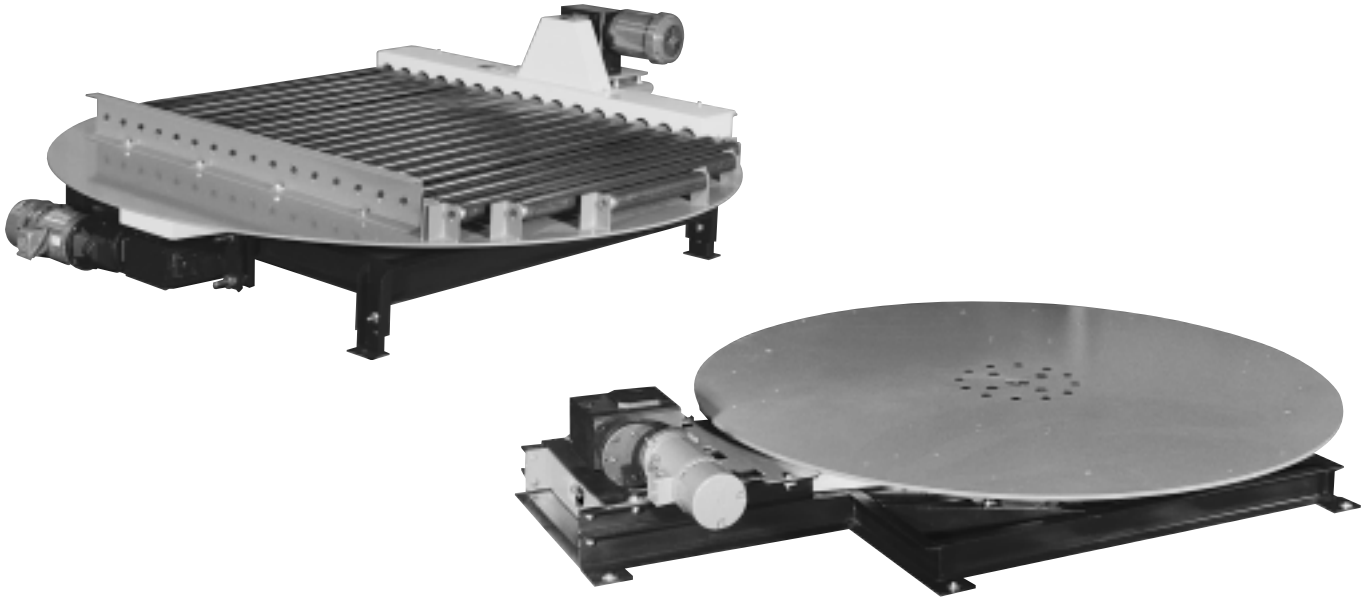

Turntables are used for loading and unloading pallets and containers, as well as improving the ergonomics of workstations.

- Light and Heavy Duty Models
- Standard Diameters up to 120 in.

- Capacities up to 10,000 lbs.
- 90°, 180°, 270° or 360° Rotation

Standard Specifications:

Base Frame - Heavy duty welded structural channel or tube provides rigid support for table top and table top supports in both light duty and heavy duty models.

Top Plate - Rigid, flat sheet top plate provides clean work surface. Turntables can be equipped with a conveyor deck, per customer specifications. Other options are available.

Rotation - Standard table rotations of 90°, 180°, 270° or 360°. Other rotations are available upon request.

Drive - Chain drive located either underneath or externally on powered turntables. Sealed worm gear "C" face reducer powered by 230/460V, 3 Ph., 60 Hz. brake motor. Drive is protected by a torque limiter on the reducer shaft. Gear drives are an option with the use of a rotary bearing, as well as air/hydraulic cylinders for 90°.

Stops - Adjustable rubber bumper stops where applicable on powered units allow positioning of table top and absorb shock upon stopping.

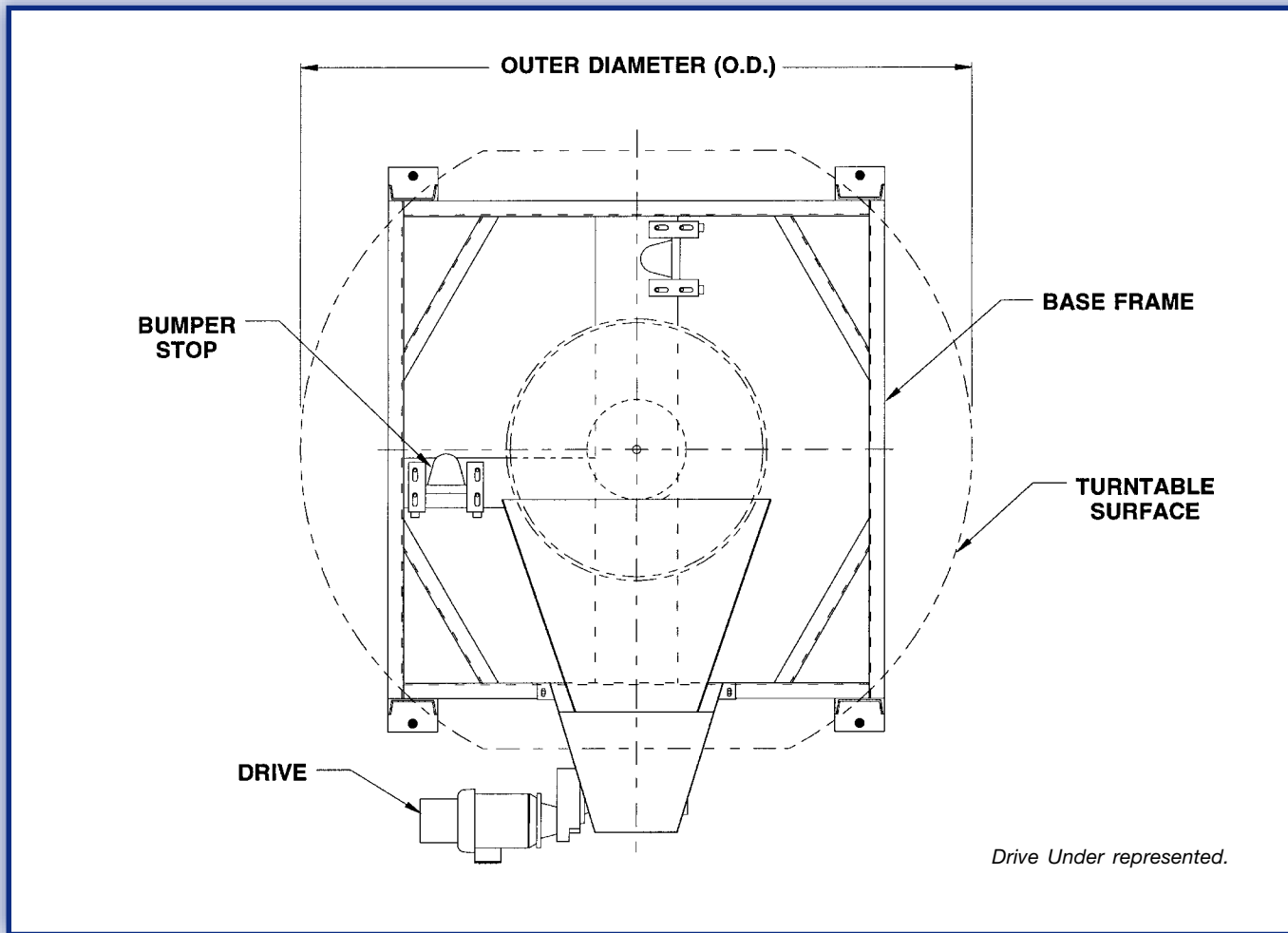

POPULAR MODELS AVAILABLE:

CAPACITY	OUTER DIA. MAX.	TOP PLATE THICKNESS	MIN. TOP OF TABLE		SUPPORT BEARING	DRIVE CHAIN	HORSE POWER	STD. SPEED AT O.D.
Powered Turntable			Drive Under	Drive External				
10,000 lbs.	120 in.	1 1/2 in.	20 in.	18 in.	Rotary Bearing	RC100	1 HP	20 fpm
7,500 lbs.	120 in.	1 in.	14 1/2 in.	12 3/4 in.	Rotary Bearing	RC80	3/4 HP	30 fpm
7,500 lbs.	120 in.	3/4 in.	16 1/4 in.	11 1/2 in.	H.D. Yoke Roller	RC80	1 HP	30 fpm
5,000 lbs.	102 in.	5/8 in.	16 in.	10 3/4 in.	H.D. Yoke Roller	RC80	3/4 HP	30 fpm
3,500 lbs.	84 in.	1/2 in.	14 in.	8 1/4 in.	H.D. Yoke Roller	RC60	1/2 HP	30 fpm
1,000 lbs.	60 in.	3/8 in.	12 in.	7 1/2 in.	Yoke Roll	RC50	1/3 HP	30 fpm

Additional capacities and sizes are available.

NOTE: Lower table heights may be available. Please consult your Omni Metalcraft sales representative.

Options:

- Limit switches or proximity switches to determine position of table top.
- A slip ring to route power through center of table to rotating deck of turntable. A slip ring may affect the minimum height of table.
- Rotary union to route air or hydraulic oil to rotating deck of turntable. Rotary unions may affect the minimum height of table.
- Inverter duty motor, air motor, hydraulic motor.
- Gravity transition rollers are standard on units that incorporate a conveyor deck. These transition rollers, which are attached to the rotating part of the turntable, are used to assist in supporting products during the transition from adjoining conveyor to the turntable. Powered transition rollers are also available to aid problem products. Fixed transition rollers can also be mounted to adjoining conveyor.

