



BEVERAGE ■
MEDICAL ■
PHARMACEUTICAL ■
CONSUMABLES ■
FOOD ■



CONVEYOR COMPONENTS

OPEN TOP

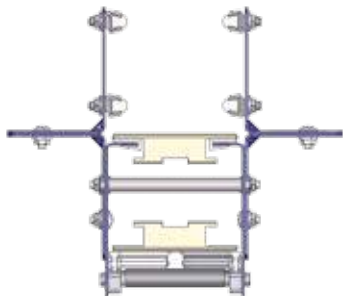

CLOSED TOP

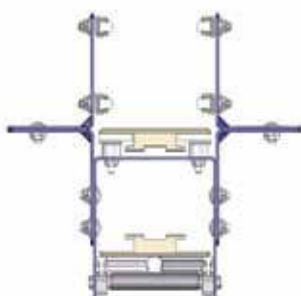

CROSS SECTIONS

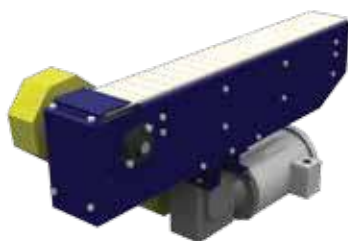

INTERMEDIATE

- 12", 18", 24", 36", 60", 92", 120" standard lengths
- Custom intermediate lengths available
- 5.5" formed frame

DRIVE END

- 3' standard length
- 8" formed frame
- 2 hole flange bearing with lubrication access
- Underhung drive mount standard with chain or timing belt
- Two piece thermoplastic sprocket
- Hollow shaft drive available

IDLE END

- 1', 2' and 3' standard lengths
- 8" formed frame
- 2 hole flange bearing with lubrication access
- Two piece thermoplastic sprocket

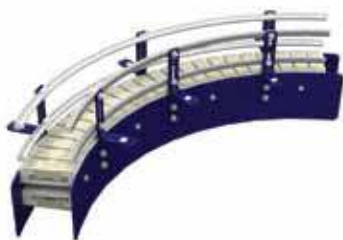

90° CURVE

- 30°, 45°, 60°, 90° curves standard
- 24" radius at centerline of chain
- Side flexing tab style chains are required
- 5.5" formed frame

COPE

- 1' standard length
- A cope is used to make a change in the conveyor elevation
- Up to 3/4" slope per foot maximum
- See engineering for custom applications

MODULAR TABLE TOP CONVEYOR

EQUIPMENT SETS

COMBINER



- A combiner is used to orient a mass flow of round product into single file
- 10' standard length
- Available with straight running and side flexing tab style chains
- Bead rail side guides optional

90° DEAD PLATE TURN

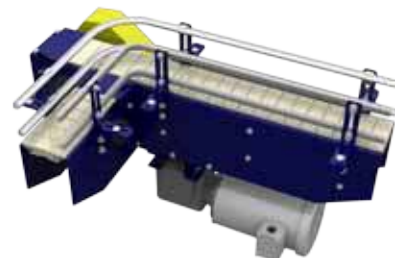

- Back pressure required to accommodate transition across dead plate
- Roller plate transitions available
- 2 hole flange bearing with lubrication access
- Available with straight running or side flexing chain

INLINE TRANSFER

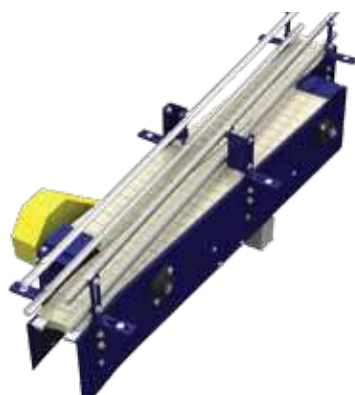

- An inline transfer is used to transition small or unstable product from one chain to another that will not convey over a dead plate
- Inline transfers maintain linear product flow direction with the use of side flexing tab chain
- Chains are spaced 1/16" apart without the use of a dead plate to ensure smooth product transition
- Side flexing tab style chains are required
- 4'-6" standard length

PARALLEL TRANSFER

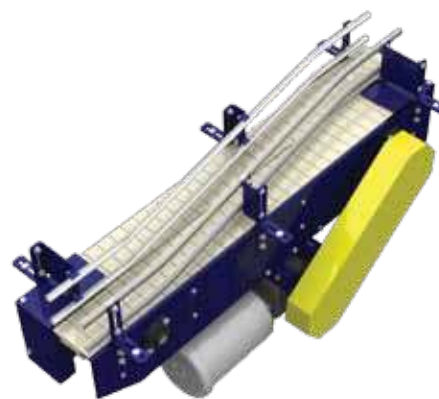

- A parallel transfer is used to transition small or unstable product from one chain to another that will not convey over a dead plate
- Parallel transfers shift product perpendicular to flow direction without side flexing tab chain
- Available with straight running and side flexing tab style chains
- Chains are spaced 1/16" to ensure smooth product transition
- 4' standard length

SPECIFICALLY UTILIZED FOR...

- Transportation
- Accumulation
- Combining
- Turning
- Diverting
- Filling
- Labeling
- Packaging

IN ENVIRONMENTS THAT ARE...

- Wet
- Dry
- Hot
- Greasy
- Exposed to chemicals
- Clean room conditions

GREAT FOR CONVEYING...

- Bottles
- Packages
- Parts
- Boxes

OmniMetalcraftcorp.

GENERALLY APPLIED IN...

- Manufacturing
- Processing



THE OMNI ADVANTAGE. Custom Saw Feeding Mill Steel Chain with Attachments Integrated with a Chain Driven Roller Takeaway Conveyor

GENERAL CONVEYOR SPECIFICATIONS

- Modular construction
- 5.5" formed angle frames, 8" on drive and idler ends
- 12 ga. stainless steel or powder coated mild steel
- Bolt together construction with tube spreaders
- Open or closed top construction
- Adjustable single high guide rail with UHMW wear strip, double high available
- Serpentine return standard, roller return available
- Two piece thermoplastic sprockets
- Shaft mount standard, underhung drive mount available
- Dead plates and roller plate transitions available
- Formed angle and welded tube style floor supports available

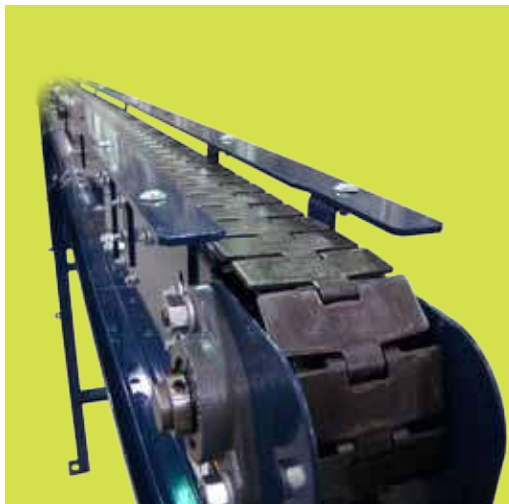

Mild Steel Chain with Custom Side Guides

STRAIGHT RUNNING CHAIN



820 LF
Chain widths
3.25", 4", 4.5", 6", 7.5"



821 LF
Chain widths
7.5", 10", 12"

SIDE FLEXING CHAIN



880 LF TAB
Chain widths
3.25", 4.5"



882 LF TAB
Chain widths
3.25", 4.5", 7.5", 10", 12"

SPECIALITY CHAIN



820 HPM

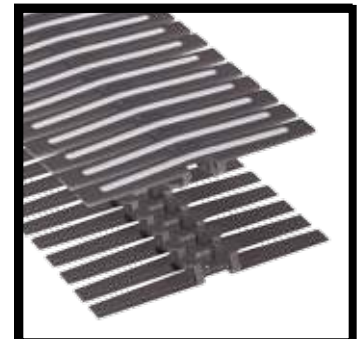

882 TAB HPM

Mild Steel and Stainless Steel Chain available