

NEMA Frame/Shaft Sizes

Frame numbers are not intended to indicate electrical characteristics such as horsepower. However, as a frame number becomes higher SC) in general does the physical size of the motor and the horsepower. There are many motors of the same horsepower built in different frames. NEMA (National Electrical Manufacturers Association) frame size refers to mounting only and has no direct bearing on the motor body diameter.

In any standard frame number designation there are either two or three numbers. Typical examples of frame numbers 48, 56, 145, and 215. The frame number relates to the "D" dimension (distance from center of shaft to center bottom of mount). For example, in the two-digit 56 frame, the "D" dimension is 3½", 56 divided by 16 = 3½". For the "D" dimension of a three-digit frame number, consider only the first two digits and use the divisor 4. In frame number 145, for example, the first two digits divided by the constant 4 is equal to the "D" dimension, 14 divided by 4 = 3½". Similarly, the "D" dimension of a 213 frame motor is 5¼", 21 divided by 4 = 5¼".

By NEMA definition, two—digit frame numbers are fractional frames even though 1 HP or larger motors may be built in them. Three-digit frame numbers are by definition integral frames. The third numeral indicates the distance between the mounting holes parallel to the base. It has no significance in a footless motor.

A summary of NEMA standard dimensions is on the next page.

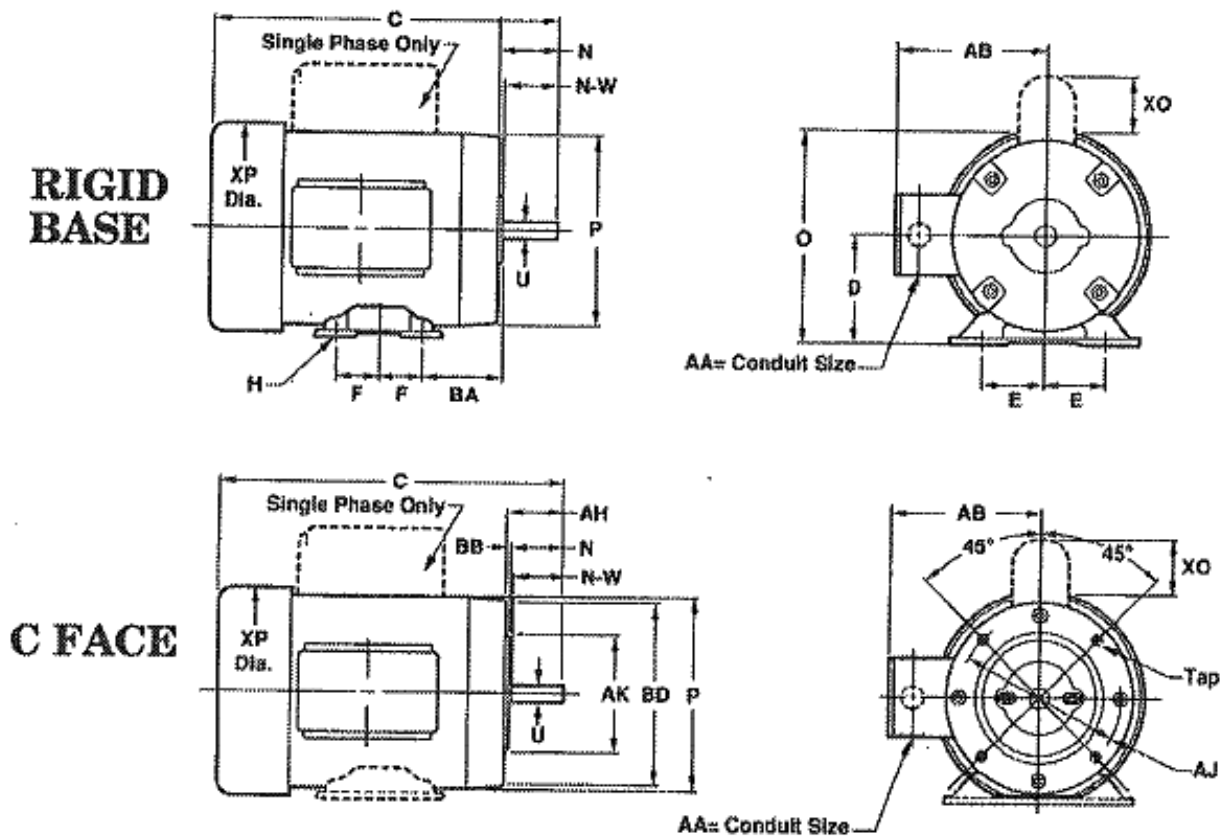

MOTOR FRAME DIMENSIONS (inches)

shaded area denotes dimensions established by NEMA standard MG-1. Other dimensions will vary among manufacturers

NEMA Frame Sizes	D	E	F	H	N	O	P	U	N-W	AA	AB	AH	AJ	AK	BA	BB	BD	XO	XP	TAP ***	KEY
42	2 5/8	1 3/4	27/32	9/32 Slot	1 1/4	5 1/16	4 7/8	3/8	1 1/8	3/8	4 1/2	1 5/16	3 3/4	3	2 1/16	1/8	4 7/8	1 5/8	5 1/8	7309	3/64 Flat
48	3	2 1/8	1 3/8	11/32 Slot	1 9/16	5 13/16	5 19/32	1/2	1 1/2	1/2	4 7/8	1 11/16	3 3/4	3	2 1/2	1/8	5	2 1/4	5 7/8	7309	3/64 Flat
S56 56	3 1/2	2 7/16	1 1/2	11/32 Slot	1 15/16	6 5/16 6 13/16	5 19/32 6 19/32	5/8	1 7/8	1/2	4 7/8 5 5/16	2 1/16	5 7/8	4 1/2	2 3/4	1/8	6 1/2	2 1/4	5 7/8 7 5/32	5912	3/16
143T 145T	3 1/2	2 3/4	2 2 1/2	11/32	2 3/8	6 13/16	6 19/32	7/8	2 1/4	3/4	5 5/16	2 1/8	5 7/8	4 1/2	*2 1/4	1/8	6 1/2	2 1/4	7 5/32	5912	3/16
182T 184T	4 1/2	3 3/4	2 1/4 2 3/4	13/32	2 7/8	8 3/4	8 15/32	1 1/8	2 3/4	3/4	6 3/8	2 5/8	7 1/4	8 1/2	*2 3/4	1/4	8 7/8	2 1/4	9 3/32	4751	5/16
S213T 213T 215T	5 1/4	4 1/4	2 3/4 2 3/4 3 1/2	13/32	3 1/2 —	9 15/16 10 11/16	8 15/32 10 13/16	1 3/8	3 3/8	3/4 1	6 3/8 8 5/16	3 1/8	7 1/4	8 1/2	*3 1/2	1/4	8 7/8 9	2 1/4	9 3/32 11 3/32	4751	5/16
254T 256T	6 1/4	5	4 1/8 5	17/32	—	12 15/16	13 1/4	1 5/8	4	1 1/4	11 5/8	3 3/4	7 1/4	8 1/2	*4 1/4	1/4	9 5/8	—	12 7/8	4751	3/8
284TS 284T 286TS 286T	7	5 1/2	4 3/4 5 1/2	17/32	—	14 1/2	14 3/4	1 5/8 1 7/8 1 5/8 1 7/8	3 1/4 4 5/8 3 1/4 4 5/8	1 1/2	11 3/4	3 4 3/8 3 4 3/8	9	10 1/2	4 3/4	1/4	11	—	14 1/2	1/2 13	3/8 1/2 3/8 1/2
324TS 324T 326TS 326T	8	6 1/4	5 1/4 6	21/32	—	15 3/4	15 3/4	1 7/8 2 1/8 1 7/8 2 1/8	3 3/4 5 1/4 3 3/4 5 1/4	2	13 1/2	3 1/2 5 3 1/2 5	11	12 1/2	5 1/4	1/4	13 3/8	—	15 3/4	5/8 11	1/2
364TS 364T 365TS 365T	9	7	5 5/8 6 1/8	21/32	—	17 13/16	17 3/8	1 7/8 2 3/8 1 7/8 2 3/8	3 3/4 5 7/8 3 3/4 5 7/8	3	15 7/16	3 1/2 5 5/8 3 1/2 5 5/8	11	12 1/2	5 7/8	1/4	14	—	17 3/4	5/8 11	1/2 5/8 1/2 5/8
404TS 404T 405TS 405T	10	8	6 1/8 6 7/8	13/16	—	19 5/16	19 1/8	2 1/8 2 7/8 2 1/8 2 7/8	4 1/4 7 1/4 4 1/4 7 1/4	3	16 5/16	4 7 4 7	11	12 1/2	6 5/8	1/4	15 1/2	—	19 3/8	5/8 11	1/2 3/4 1/2 3/4
444TS 444T 445T 447TZ	11	9	7 1/4 7 1/4 8 1/4 10	13/16	—	22 1/4	22	2 3/8 3 3/8	4 3/4 8 1/2 8 1/2 10 1/8	3	21 11/16	8 1/4	14	16	7 1/2	1/4	18	—	19 3/8	5/8 11	5/8 7/8 7/8 7/8