

Chain Transfers



Omni
Metalcraft
CORP

CHAIN TRANSFERS

Heavy Duty Chain Transfers	231
Pivot Chain Transfer	231
Reversible Six-Strand Chain Transfer	231
Standard Models Chain Transfer	232

CHAIN CONVEYORS

Standard Models	233
-----------------------	-----

Chain Transfers

Chain Transfers are used to transfer products 90° onto an adjacent conveyor. They are ideal for pallets or other products with a sturdy conveying surface.



- Air Bag or Cylinder Cam Actuated
- Standard Capacities up to 8000 lbs.
- Available 12 in. Top of Roller Height (Consult Engineering)
- Built to Your Specifications

Heavy Duty Chain Transfers Built to Your Specifications

Omni Metalcraft Corp. offers custom chain transfers built to your specific requirements. These examples demonstrate how we can handle your tough material handling applications.

Pivot Chain Transfer

- 35,000 lb. Capacity
- 6 in. Pitch Chain
- Six 16 in. dia. Air Bags
- 20 in. Top of Chain
- Fork Entrance Guides

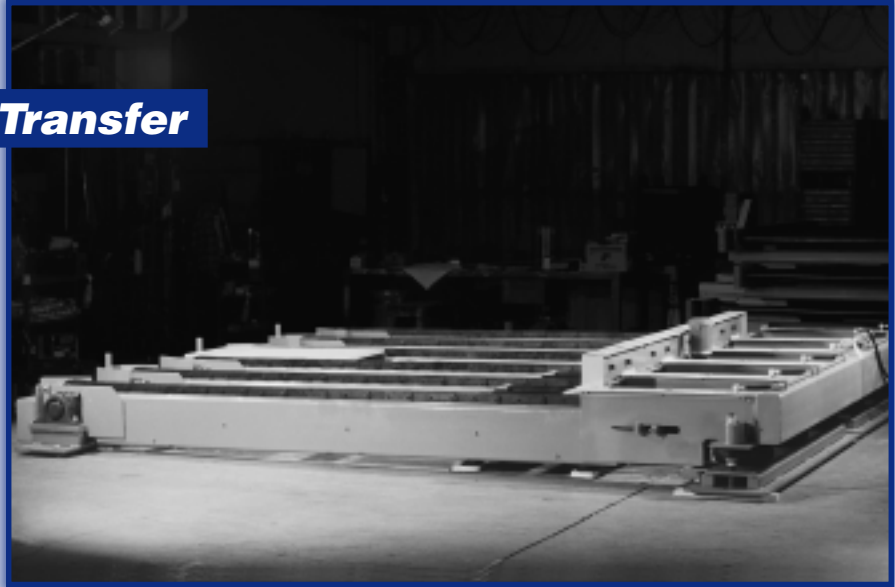

Reversible Six-Strand Chain Transfer

- 20,000 lb. Capacity
- 6-1/2 in. Diameter Rollers
- Pop-Up CDLR Conveyors
- RC120 Conveying Chain



Chain Transfers

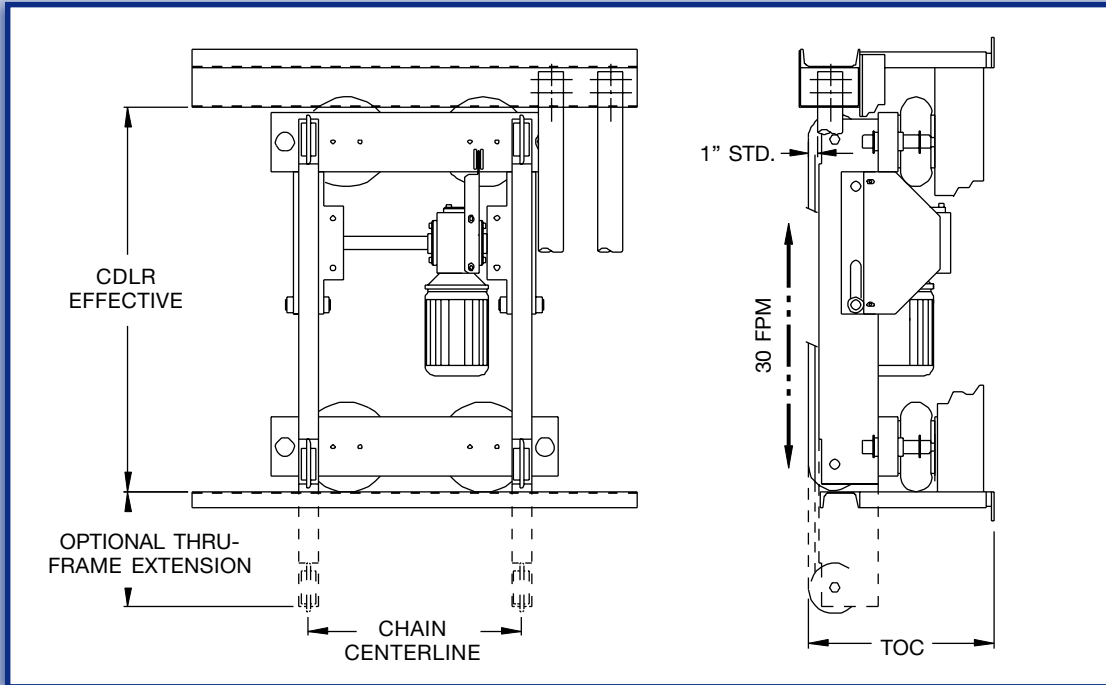

STANDARD MODELS AVAILABLE:

MAX. CAPACITY	CHAIN TYPE	CHAIN TRACK	MIN. TOP OF CHAIN	MIN. ROLLER CENTER (at Chains)	HORSE POWER
500 lbs.	C50	UHMW	15"	1.9 in. dia. = 4-3/8" 2-1/2 in. dia. = 5-5/16"	1/2
1500 lbs.	C60	UHMW	16"	2-1/2 in. dia. = 6" 3-1/2 in. dia. = 7-1/2"	1/2
2000 lbs.	C60	UHMW	16"	2-1/2 in. dia. = 6" 3-1/2 in. dia. = 7-1/2"	3/4
3000 lbs.	C80	UHMW	18"	2-1/2 in. dia. = 6-3/4" 3-1/2 in. dia. = 7-1/2"	1
4000 lbs.	C80	STEEL	19"	2-1/2 in. dia. = 6-3/4" 3-1/2 in. dia. = 7-1/2"	2
6000 lbs.	C100	STEEL	19"	3-1/2 in. dia. = 8-1/2" 4 in. dia. = 9"	3
8000 lbs.	RC120	STEEL	28"	3-1/2 in. dia. = 8-1/2" 4 in. dia. = 9"	5

Additional Capacities and Sizes are Available.
(Chart is based on 2 strand @ 30 f.p.m.)

Standard Specifications:

Conveyor Frame - Heavy duty welded construction with structural tube chain rails.

Chain Track - UHMW polyethylene on C50, C60 and C80 sizes (up to 3000 lbs.) provides wear resistance, quiet operation and reduces power requirements. Special alloy steel track on C80 (3000 lbs. and up), C100 and RC120 sizes for increased load capacity.

Conveying Chain - "C" series, straight side-bar chain on sizes C50 through C100 is used. This flat plate chain reduces product damage and wear compared to traditional roller chain.

Padded Chain - Transfer chain with non-marring pads assembled to the chain. Glass or painted parts are just some of the products that can be conveyed on this chain.

Belts - Polyurethane v-belts or flat belts are available for non-marring applications.

Lift - AIR BAG (Std.) Simple, maintenance-free airbags are plumbed to a common air connection.

CAMS (Optional) Heavy duty cylinder or electric operated cams are available to accommodate products that require level lifting.

Drive - Center-mounted drive allows chain travel to be reversed. Drive and pinch points are guarded.

Options -

- Limit switches
- Single solenoid valves
- Three or more chain strands
- Many other options also available

Chain Conveyors

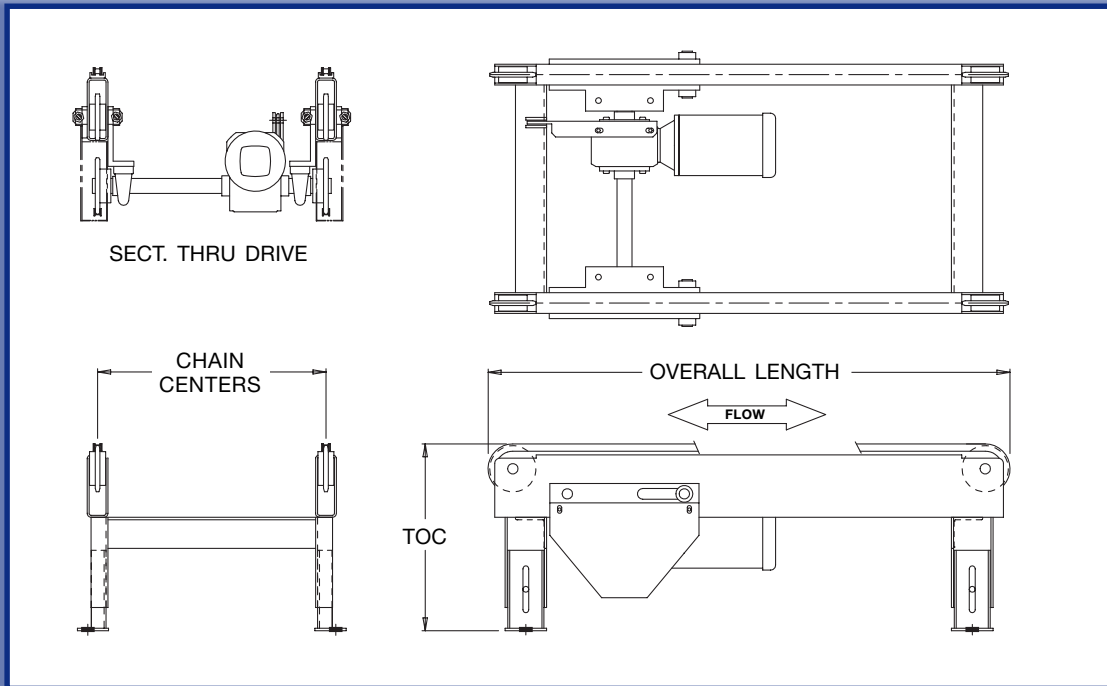

STANDARD MODELS AVAILABLE:

MAX. CAPACITY	CHAIN TYPE	CHAIN TRACK	MIN. TOP OF CHAIN	MIN. CHAIN CENTERS	HORSE POWER
500 lbs.	C50	UHMW	10"	8"	1/2
1500 lbs.	C60	UHMW	14"	9"	1/2
2000 lbs.	C60	UHMW	14"	9"	3/4
3000 lbs.	C80	UHMW	15"	14"	1
4000 lbs.	C80	STEEL	16"	16"	2
6000 lbs.	C100	STEEL	18"	36"	3
8000 lbs.	RC120	STEEL	24"	27"	5

Additional Capacities and Sizes are Available.
 (Chart is based on 2 strand @ 30 f.p.m.)

Standard Specifications:

Conveyor Frame - Heavy duty welded construction with structural tube chain rails.

Chain Track - UHMW polyethylene on C50, C60 and C80 sizes (up to 3000 lbs.) provides wear resistance, quiet operation and reduces power requirements. Special alloy steel track on C80 (3000 lbs. and up), C100 and RC120 sizes for increased load capacity.

Conveying Chain - "C" series, straight side-bar chain on sizes C50 through C100 is used. This flat plate chain reduces product damage and wear compared to traditional roller chain.

Padded Chain - Transfer chain with non-marring pads assembled to the chain. Glass or painted parts are just some of the products that can be conveyed on this chain.

Belts - Polyurethane v-belts or flat belts are available for non-marring applications.

Drive - Center-mounted drive allows chain travel to be reversed. Drive and pinch points are guarded.

